

A multi-station magnetotelluric study in southern Scotland — I. Fieldwork, data analysis and results

Alan G. Jones^{*} and Rosemary Hutton *Department of Geophysics,
University of Edinburgh, UK*

Received 1978 July 10; in original form 1978 February 28

Summary. Magnetotelluric measurements have been made at 13 locations in southern Scotland along lines perpendicular and parallel to the strike of a major electrical conductivity anomaly detected by previous geomagnetic deep sounding studies.

Following a brief account of the fieldwork and data analysis procedure, the justification for one-dimensional interpretation at certain sites is presented. Six of the 13 sites fall into this category. Their magnetotelluric responses were found to fall into three groups which appear to be representative of (a) the Midland Valley, (b) the Southern Uplands and (c) northern England. Limited forward modelling of the well-estimated data was undertaken and is discussed in this paper. It indicates marked lateral variations in conductivity structure across the region.

1 Introduction

The existence of an electrical conductivity anomaly in southern Scotland was first suggested by Osemeikhian & Everett (1968) who noted attenuation in the vertical magnetic field component in their shortest period data, $T \sim 12$ min, at Eskdalemuir and Glenlee, but not at their other stations in southern Scotland. A more intensive study of the region using magnetometers of similar sensitivity led Edwards, Law & White (1971) to confirm the existence of an 'Eskdalemuir Anomaly', of strike north-east–south-west, at lower crustal or upper mantle depths. As possible explanations of the anomaly, they suggested (a) a compositional change, at an unknown depth, such that there was an increased fayalite content in the olivine, (b) high water content of deformed water-deposited sediments, or (c) graphitic schists existing at depths. In a revised interpretation of the same data using the hypothetical event technique (Bailey *et al.* 1974), Bailey & Edwards (1976) concluded that a good electrical conductor existed at lower *crustal* depths and was compatible with the presence there of the remnants of the proto-Atlantic Ocean (Dewey 1974). The existence of a conducting layer at lower crustal depths at Eskdalemuir and in the Irish Sea near Stranraer,

^{*} Present address: Institut für Geophysik der Westfälischen Wilhelms-Universität, D-4400 Münster/Westf., Gievenbecker Weg 61, West Germany.

had previously been suggested by magnetotelluric measurements at these locations (Jain & Wilson 1967).

Lateral variations in the depth of the crustal seismic refractors and of the Moho discontinuity have also been detected in the Lithospheric Seismic Profile in Britain (LISPB) by Bamford *et al.* (1976) for this region. They further noted that the Moho discontinuity changed in nature from a sharp transition under the northern part of the Midland Valley to a gradational change (over 5 km depth) under the Southern Uplands.

The tectonic history of southern Scotland has been a subject of much controversy during the past decade, following the suggestion by Wilson (1966), from consideration of faunal realms, of the existence of an ocean – the Iapetus or Proto-Atlantic – between Scotland and England during early Palaeozoic times. There is substantial palaeomagnetic evidence (Briden, Morris & Piper 1973) that this separation between the two continental masses was eliminated by the end of the Caledonian orogeny (*c.* 360 Myr) but none of the several plate tectonic models (Moseley 1977), proposed to explain the processes involved in the closure, has yet received general acceptance.

As there is increasing evidence of a close correlation between electrical conductivity anomalies and both past and present tectonic activity (Law & Riddihough 1971; Gough 1973; Garland 1975; Hutton 1976), it was decided to undertake intensive electromagnetic induction studies in southern Scotland. These comprised a two-dimensional geomagnetic deep sounding array study (Hutton, Sik & Gough 1977) using Gough–Reitzel magnetometers of sensitivity 1 nT and a period band of approximately 4 min to DC and single station magnetotelluric and magnetovariational studies using magnetometers of sensitivity 0.01 nT and a period band of 10–10 000 s. The results of the short-period magnetovariational study and some preliminary magnetotelluric results have already been reported (Jones & Hutton 1977; Hutton & Jones 1978). In this paper, the magnetotelluric observations are presented more fully and the results of preliminary mathematical modelling of six representative stations are discussed. In part II, a Monte-Carlo inversion procedure is developed and applied to the magnetotelluric data from these six stations. The geophysical and geological significance of the resulting conductivity models is considered in this second paper.

2 The magnetotelluric project

The locations at which the observations – time variations of three components of the magnetic field and two horizontal components of the electric field – were made is shown in Fig. 1. They were chosen such that the main transverse from FTH to TOW was approximately perpendicular to the strike of the anomaly as suggested by previous workers (*i.e.* north-west–south-east) and the second traverse PRE to TIN lay along the proposed anomaly (*i.e.* north-east–south-west). The observations at SAL were undertaken to provide information about the extent to which any ‘coast effect’ might perturb the observations at PRE, GOR and TIN. The geographic coordinates and the recording periods are given for each site in Table 1. Two independent MT systems were available – one for short-period (either (a) 10–300 s or (b) 10–1200 s) variations (Fast Variation System, FVS) and the other for recording the more slowly varying phenomena (200 s to 24 hr) – but the longer-period system (Slow Variation System, SVS) was not used at all sites, due to the much longer observation time required to obtain sufficient good quality data. This was approximately 3 weeks for the SVS and 1 week for the FVS. Block diagrams of the two systems and their frequency responses are shown in Fig. 2.

The results of the calibration of the systems, other instrumental details and comments about problems which arose during the fieldwork are given in Jones (1977).

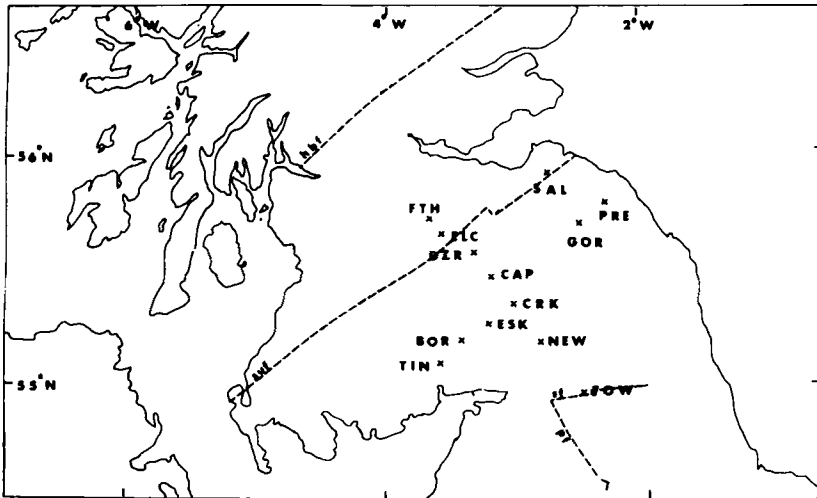

Figure 1. Map showing the location of the MT sites. hbf – Highland Boundary Fault; suf – Southern Uplands Fault; sf – Stublick Fault; pf – Pennine Fault.

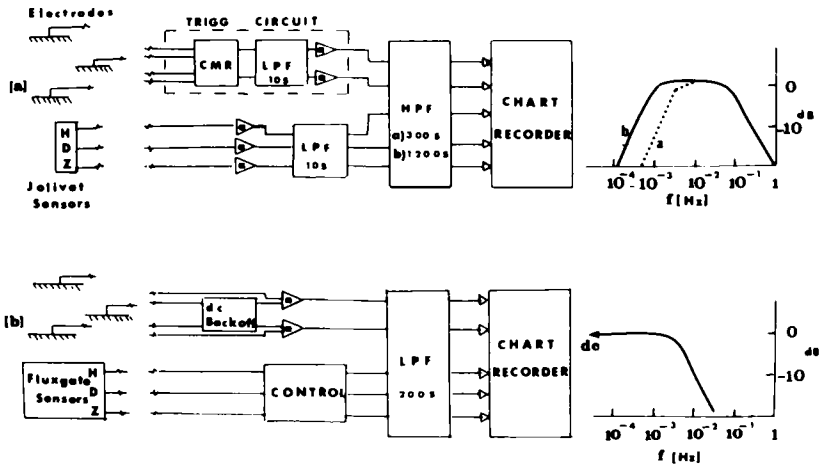

Figure 2. Block diagrams of the magnetotelluric systems and their frequency responses. (a) Fast Variation System – the telluric system is based on that described by Trigg, Serson & Camfield (1971). (b) Slow Variation System.

3 Data analysis

3.1 GENERAL CONSIDERATIONS

A high signal/noise ratio was the main criterion for the selection of data sections for digitization from each site, but consideration was also given to the time of day and the dominant polarizations of the sections. These latter criteria were employed to ensure that the averaged impedance estimates would not be biased by particular source field structures, but would represent ensemble averaging of independent information. The selected data sections were digitized on a Ferranti Freescan Digitizer table at digitizing intervals which would not introduce aliasing errors – 2, 4 and 60 s for the FVSa, FVSb and SVS systems respectively. Between 15 and 30 hours of FVS data were analysed in this way for each station.

Table 1. Magnetotelluric station data.

Station title	Station name	Geographic coordinates	Recording period (not always continuous)
BOR	Borland	3.324 W 55.224 N	FVS 24/04/75–01/05/75
CAP	Cappercleuch	3.217 W 55.364 N	FVS 02/04/75–10/04/75
CRK	Craik	3.025 W 55.364 N	FVS 06/08/74–11/08/74 SVS 06/08/74–24/08/74
DZR	Drumelzier	3.390 W 55.595 N	FVS 18/09/74–28/09/74 SVS 15/09/74–03/10/74
ELC	Elsrickle	3.533 W 55.664 N	FVS 24/03/75–30/03/75 SVS 24/03/75–11/04/75
ESK	Eskdalemuir	3.200 W 55.314 W	FVS 05/08/75–11/08/75
FTH	Forth	3.681 W 55.782 N	FVS 29/08/74–03/09/74 SVS 26/08/74–12/09/74
GOR	Gordon	2.533 W 55.686 N	FVS 16/05/75–23/05/75 SVS 16/05/75–09/06/75
NEW	Newcastleton	2.796 W 55.196 N	FVS 04/05/75–09/05/75 SVS 04/05/75–12/05/75
PRE	Preston	2.255 W 55.836 N	FVS 04/06/75–09/06/75
SAL	Saltoun	2.853 W 56.910 N	FVS 26/05/75–03/06/75
TIN	Tinwald	3.561 W 55.110 N	FVS 16/04/75–23/04/75 SVS 16/04/75–02/05/75
TOW	Towhouse	2.369 W 54.968 N	FVS 16/10/74–24/10/74 SVS 06/10/74–24/10/74

Pre-processing of each time series involved the removal of a quadratic trend, application of a cosine taper to the first and last 10 per cent of the data and augmentation with zeros to provide data sets of length a power of 2. After Fourier transformation of each data set into the frequency domain (by the SSP routine RHARM), the following parameters were computed:

- (a) frequency-band averaged auto and cross spectral densities,
- (b) magnetic and telluric field polarization parameters (Fowler, Kotich & Elliot 1967),
- (c) magnetic field transfer functions,
- (d) Cagniard apparent resistivities,
- (e) unrotated and rotated tensor impedances (Reddy & Rankin 1974; Rankin *et al.* 1976).

Fig. 3(a) is a block diagram of the procedural steps involved in the main analysis programme (Programme One). A constant Q window (Swift 1967; Vozoff 1972; Reddy *et al.* 1976) was applied to frequency band average the raw spectral estimates and corrections were applied for the effects of parallax and of the filter responses. Each time series was also subjected to the analysis outlined in the block diagram in Fig. 3(b). By means of this frequency-time analysis, which is described in full by Jones (1977), it was possible to select sub-data sets which displayed the characteristics desired, e.g. high signal/noise ratio, high coherence or a particular horizontal magnetic field polarization. In some cases, Programme Two produced acceptable short-period estimates which could not have been

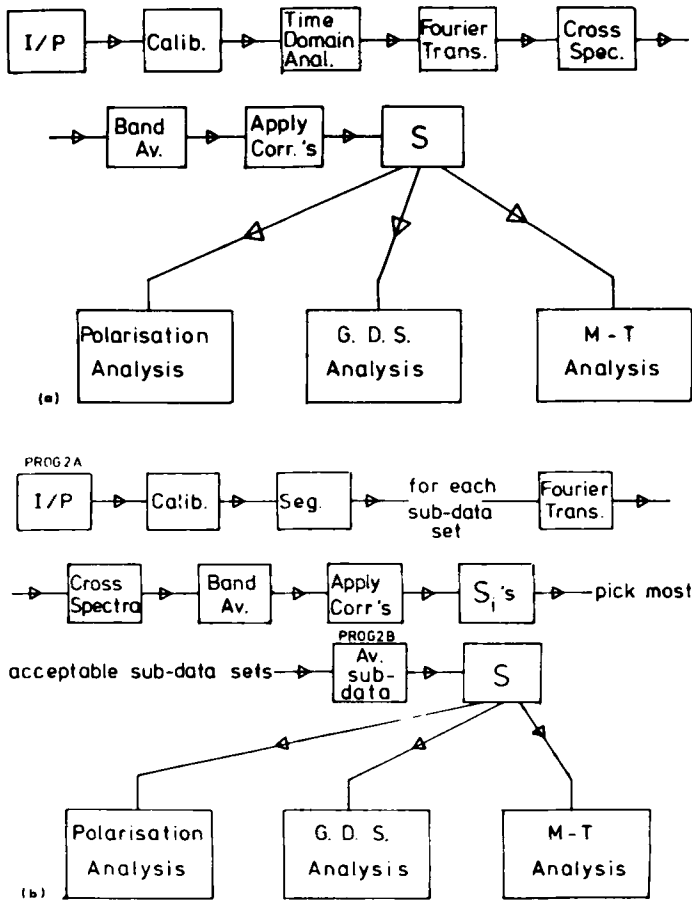

Figure 3. Block diagrams of the computer programs. (a) The main data analysis program. (b) the program for selecting sub-data sets.

obtained by means of Programme One analysis alone. Although equivalent to a sonogram analysis, as used by Swift (1967), Hermance (1973) and Grillot (1975) in similar studies, this frequency-time analysis required less computing time and file space and less effort on the part of the investigator than a time-domain sonogram approach involving a bank of narrow band-pass filters. For example, application of Programme One to data section PRE 4 (Fig. 4) had yielded no acceptable apparent resistivity or phase estimates for periods less than 50 s because the smoothed auto-spectral density of one or more of the traces was less than the estimated digitizing error power. Fig. 5 shows the frequency-time variations of the power acceptance regions for the MT analysis of this event. They indicate high signal levels down to periods as short as 20 s for sub-sets 4, 5 and 6 which could thus be input to PROG 2B.

3.2 MAGNETOTELLURIC IMPEDANCE ESTIMATION

Following the procedure adopted by many workers (e.g. Swift 1967; Kurtz 1973; Rooney & Hutton 1977) both the Cagniard impedances and the tensor impedance estimates Z_{ij}

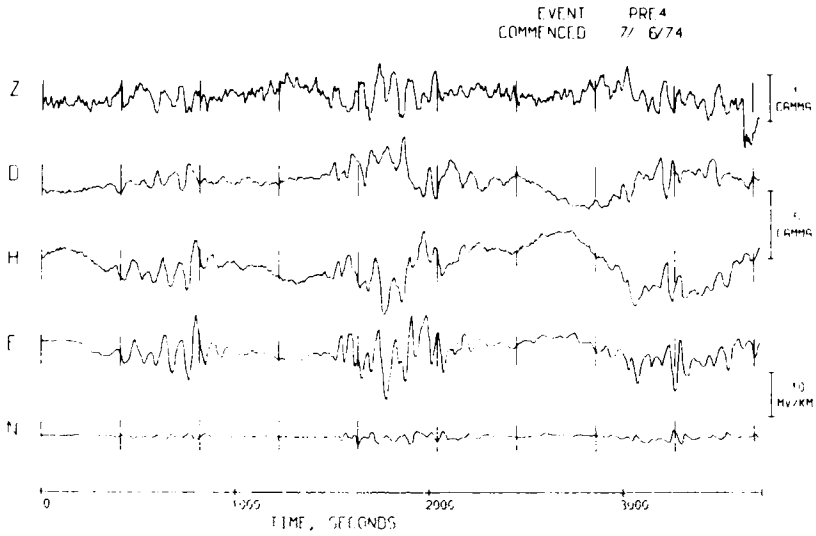

Figure 4. Data section for Preston, event 4 - PRE 4.

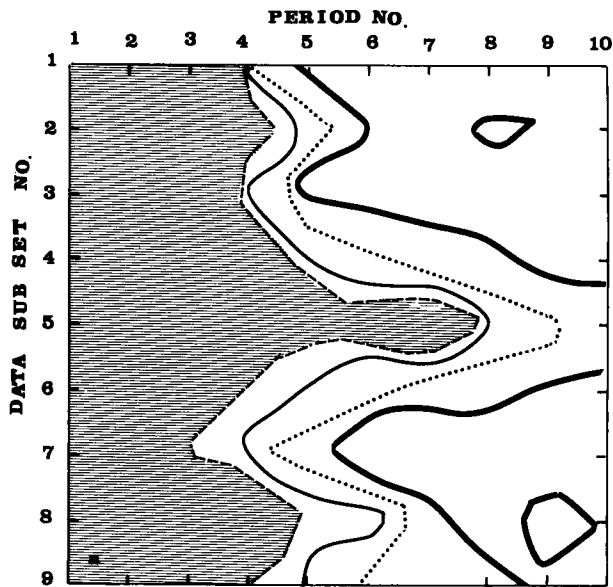

Figure 5. Example of the contour plots of frequency-time analysis of data section PRE 4. The periods represented by the period numbers are as follows:

No.	1	2	3	4	5	6	7	8	9	10
Period(s)	523	149	65	40	30	24	20	16	13	11

Contours of minimum acceptable power for the MT analysis are plotted: - - - - *H* magnetic component, *D* magnetic component, ——— north-south telluric component, ——— east-west telluric component. The shaded region indicates the period bands and data sub-set numbers for which there is acceptable power in all four components.

were determined from

$$\begin{bmatrix} E_x \\ E_y \end{bmatrix} = \begin{bmatrix} Z_{xx} & Z_{xy} \\ Z_{yx} & Z_{yy} \end{bmatrix} \begin{bmatrix} H_x \\ H_y \end{bmatrix}$$

using expressions which were least biased by noise in the telluric field observations (see Sims, Bostick & Swift 1971).

After computation in the original coordinate system, rotated estimates were derived from the matrix equation

$$\mathbf{Z}' = \mathbf{R}\mathbf{Z}\mathbf{R}^T$$

where \mathbf{R} is the Cartesian rotation matrix

$$\mathbf{R} = \begin{bmatrix} \cos \theta & \sin \theta \\ -\sin \theta & \cos \theta \end{bmatrix}.$$

In this study the method of rotation was similar to the one suggested by Reddy & Rankin (1974), except that the partial coherence function $\hat{\gamma}_{32,1}^2(\theta)$ was maximized rather than minimizing $\hat{\gamma}_{31,2}^2(\theta)$, i.e. the coherence between the north (N or 3) telluric component and the east (D or 2) magnetic component, with the influence of the north (H or 1) magnetic component removed in a least-squares sense (Jenkins & Watts 1968, p. 489), was maximized rather than minimizing the coherence between N and H with the effect of D removed, $\hat{\gamma}_{31,2}^2(\theta)$. This rotation provides both the angle which indicates the gross structural strike and the direction which gives the most coherent signals of the Cagniard-like form. These can then be subjected to a one-dimensional interpretation. A comparison of this method of rotation with that which maximizes $|Z'_{xy}(\theta)|$ is given by Jones (1977). As it was not possible to deduce an analytic expression for the angle which maximized $\hat{\gamma}_{32,1}^2(\theta)$, it was necessary to rotate the function by 2° increments from 0 to 180° . The impedance Z'_{xy} – the impedance at the angle which maximized $\hat{\gamma}_{32,1}^2$ – was termed the ‘major’ impedance and Z'_{yx} the ‘minor’ impedance.

3.3 STATION DATA AVERAGING

The data from all analysed record sections from a station were first tested for acceptability, as indicated below. Those which were accepted were then assigned to period bands and all data in each band were averaged by the relevant algorithm.

There were four acceptance criteria for the MT data, namely:

(a) the maximized partial coherence function $\hat{\gamma}_{32,1}^2(\theta_0)$ had to be greater than that possible for random data (to a 95 per cent confidence level),

(b) The partial coherence function $\hat{\gamma}_{32,1}^2$ had to be greater than the partial coherence function $\hat{\gamma}_{31,2}^2$ (also to a 95 per cent confidence level),

(c) the power of each of the four MT components had to be greater than the digitizer error power,

(d) the phase of the major impedance tensor element, $\hat{Z}_{xy}(\theta_0)$ had to be between 0 and 90° .

Acceptable data for each period band from approximately 10 sections from each station were then averaged in a weighted manner, and 95 per cent confidence limits were obtained for each of the averaged parameters (Jones 1977).

4 Results

4.1 INTRODUCTION

For eight of the 13 stations, the results appear to fall into three distinct groups which are consistent with separating the stations according to locality, i.e. FTH and SAL in the Midland Valley, BOR, CRK, ESK, NEW and PRE in the Southern Uplands and TOW in northern England.

The results from these stations are discussed region by region in the following sections. The data from the remaining five stations yielded impedance values which were either poorly estimated or were inconsistent with those for the region as a whole, as discussed in Section 4.5. Those estimates derived by averaging four or more individual estimates were considered 'well-estimated' and were subsequently interpreted. Those from three or less were noted but were, in essence, disregarded. The authors realise that this approach may be more conservative than is strictly necessary, but they consider that they are, as a result, fully justified in their interpretation of the observed 'well-estimated' responses.

The 95 per cent confidence intervals for both the amplitude and phase of the 'well-estimated' data were derived by applying the usual statistical methods for distributions with unknown variance (Jenkins & Watts 1968; Mardia 1972). For the remaining data for which three or less independent estimates were averaged, the confidence intervals were determined using an algorithm developed by Jones (1977). As this algorithm was not completely appropriate to tensorial magnetotelluric analysis, the resulting confidence limits were underestimated. As a result, in some cases, the less 'well-estimated' data appear to infer less scatter than the 'well-estimated' data.

4.2 THE MIDLAND VALLEY RESPONSE

The 'well-estimated' apparent resistivity and phase data for stations FTH and SAL are illustrated in Fig. 6, and *all* the major and minor estimates for FTH in Fig. 7(a) and (b) and for SAL in Fig. 7(c) and (d). The period range covered by the responses is from 28.5 s (at SAL) to 800 s (at FTH).

The similarity of the two responses (Fig. 6) is striking. Both exhibit a major apparent resistivity of about $60 \Omega\text{m}$ and a phase response of about 50° at a period of 60 s. With increasing period, the apparent resistivities both increase and the phases decrease, to $100 \Omega\text{m}$ and 30° respectively at 700 s. The 95 per cent confidence limits of the ρ_{major} and ϕ_{major} values for both stations are small. The SAL curves appear smoother but this is probably due to the greater amount of data analysed and the correspondingly greater number of accepted estimates.

The ρ_{minor} curves from both locations also agree, with a rise from $10 \Omega\text{m}$ at periods less than 100 s to $100 \Omega\text{m}$ at periods greater than 1000 s. The anisotropy ratio ($\rho_{\text{major}}/\rho_{\text{minor}}$) at both sites is between 5–10 at short periods but reduces to 1 for periods longer than about 200 s.

The azimuthal rotation angle at both locations appears frequency independent with an approximately east–west orientation, and the skew factors are below 0.5 at all periods. According to Swift's (1967) criteria, this indicates that the geological structures beneath these two sites can be described as 'weakly' two-dimensional.

The similarity of the SAL and FTH responses suggest that the deduced impedances for SAL have not been perturbed by the coast effect.

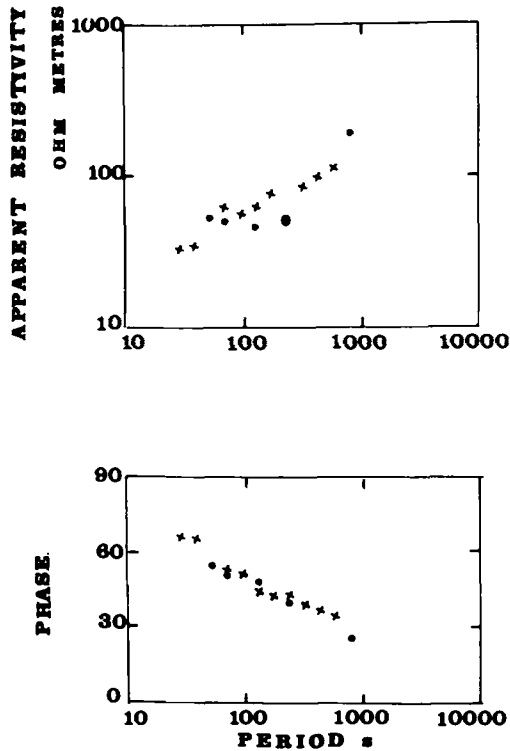

Figure 6. Apparent resistivity and phase variations with period for Forth, FTH (dots) and Saltoun, SAL (crosses) – the well-estimated values only are plotted and 95 per cent confidence limits are omitted for clarity.

4.3 SOUTHERN UPLANDS RESPONSE

Stations which, in general, display the 'Southern Uplands' response are BOR, CRK, ESK, NEW and PRE, but only data from PRE, BOR and NEW have been considered satisfactory for interpretation for reasons discussed in Section 4.5.

The well-estimated ρ_{major} and ϕ_{major} data from BOR, NEW and PRE are illustrated in Fig. 8, and the full major and minor data in Fig. 9(a) and (b) (BOR), 9(c) and (d) (NEW) and 9(e) and (f) (PRE). The major impedances from these three stations are very similar in both amplitude and phase responses. All the 'well-estimated' resistivity estimates, and the majority of the phase estimates, have very small associated confidence limits. For all three locations, the skew factor is less than 0.2 at all periods, and less than 0.1 for the majority of periods – Fig. 10(a)–(c). Hence, it can be concluded that the conductivity distribution beneath these sites is one- or two-dimensional.

Stations BOR and NEW have many other features in common. Their rotated minor resistivity estimates, except at short periods, are within the confidence limits of the major estimates at the same period. Also, their anisotropy ratios are very close to one for all periods and many of their azimuthal angles pass the Rayleigh uniform distribution test (Batschelet 1965). These features all suggest that the conductivity distribution beneath BOR and NEW is one-dimensional.

The data from PRE are anisotropic in that the ρ_{major} and ρ_{minor} curves are dissimilar. Also there is a high scatter of the ρ_{minor} estimates as indicated by the large confidence

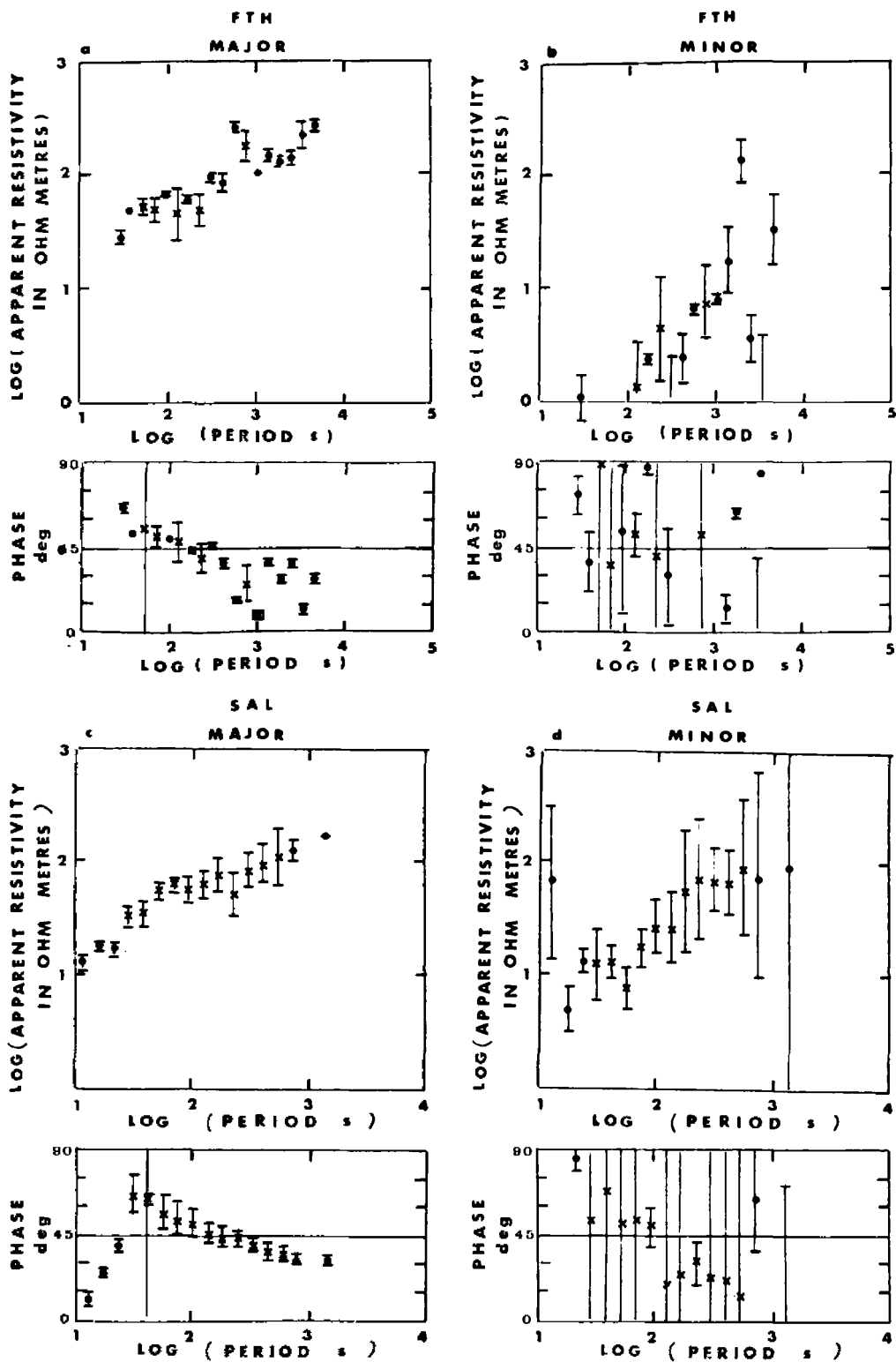

Figure 7. Rotated major and minor magnetotelluric responses for FTH (a) and (b) and SAL (c) and (d). The well-estimated values are indicated by crosses and the others by dots. 95 per cent confidence limits are shown.

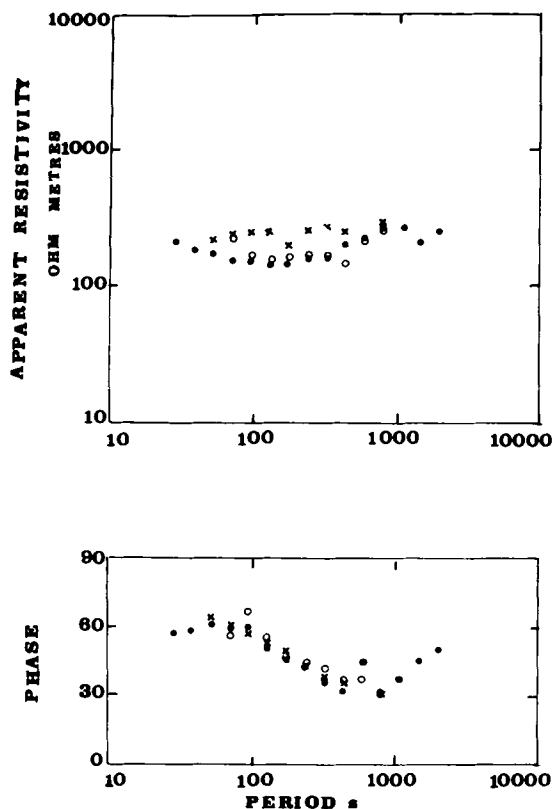

Figure 8. Apparent resistivity and phase variations with period for Borland, BOR (open circles), Newcastleton, NEW (dots) and Preston, PRE (crosses) – well-estimated values only are drawn.

intervals. Since for many of the data sections analysed, there was high-frequency noise on the east magnetic component (D), it was expected that the maximizing coherence angle, θ_{\max} , would be roughly east–west, corresponding to ρ_{major} as estimated from the east telluric (E) and the north magnetic (H) components. This is observed in practice. Also, the ρ_{minor} estimates were expected to be under-estimated at short periods due to the random noise on the D component (Sims *et al.* 1977). This may account for the observed ρ_{minor} response from PRE.

4.4 NORTHERN ENGLAND RESPONSE

The response observed at the one station in northern England, TOW, was unusual in many respects. Although a dominant orientation of the telluric field, with a high ellipticity of polarization, is commonly observed on MT records, it is not typical to find the polarization of the horizontal magnetic field as linear as that found at TOW. The power in the magnetic field was, during the whole of the 3-week recording period, almost always oriented in a north–south direction, irrespective of the nature of the field. The telluric field was also linearly polarized but with an east–west azimuth. Accordingly, the θ_{\max} direction is east–west and ρ_{major} is estimated from the H magnetic and the E telluric components. A corresponding linear polarization of the magnetic field in a north–south direction was

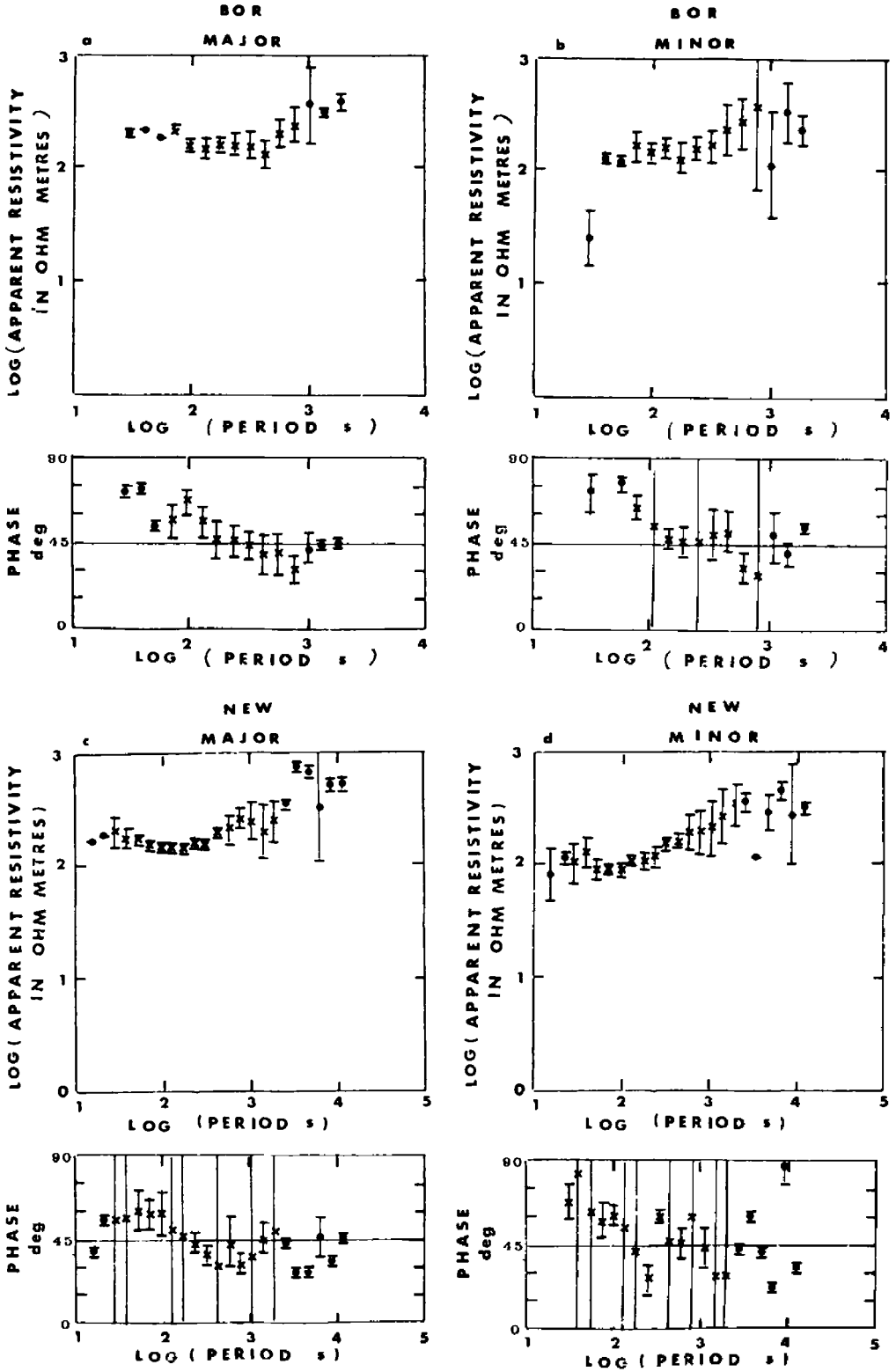

Figure 9. Rotated major and minor magnetotelluric responses for BOR (a) and (b), NEW (c) and (d) and PRE (e) and (f). 95 per cent confidence limits are shown.

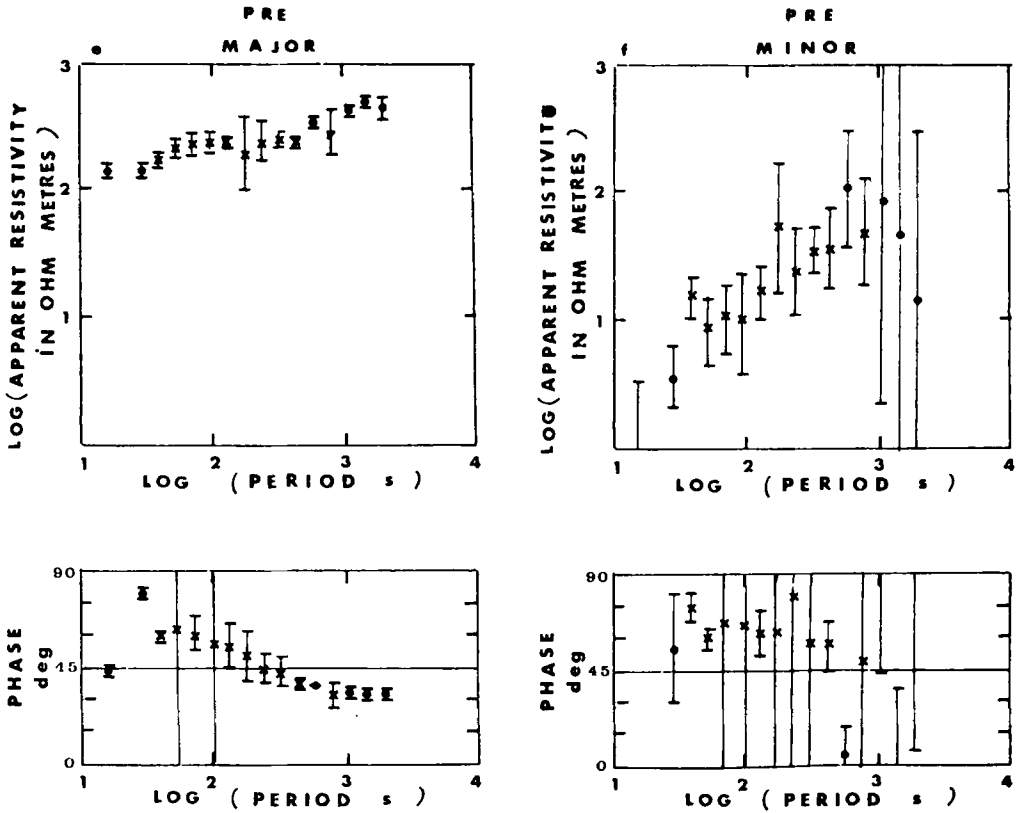

Figure 9 - continued

observed in this region - at station HAG - during the analysis of data from a recent magnetometer array study.

The rotated major and rotated minor responses observed at TOW are illustrated in Fig. 11. The ρ_{major} and ϕ_{major} estimates are very different from those observed at any other location. At short periods ($T \sim 200$ s), the major apparent resistivity is of the order of $10 \Omega\text{m}$. It increases, with increasing period, to $200 \Omega\text{m}$ at 1500 s. The major phase is less at all periods than that observed at any other location. Because there was little power in either the D magnetic or N telluric components, the ρ_{minor} values are not well estimated. This is exhibited by their large confidence intervals and their high degree of scatter with period. Large skew factors and associated large confidence intervals were obtained for TOW. This must also result from the power being contained solely in one component of each field.

4.5 RESPONSES FROM OTHER STATIONS

Large confidence limits were obtained for the CRK resistivity data. These make interpretation of its responses susceptible to much ambiguity. Also, very large skew values, which may, in this case, have been caused by the topography of the recording site, were observed at the location. Accordingly, it was considered that a full interpretation of the CRK MT results was not yet possible. Since the modelling studies have, so far, been limited to variations in conductivity with depth only, the MT results from ELC, which is located close to the

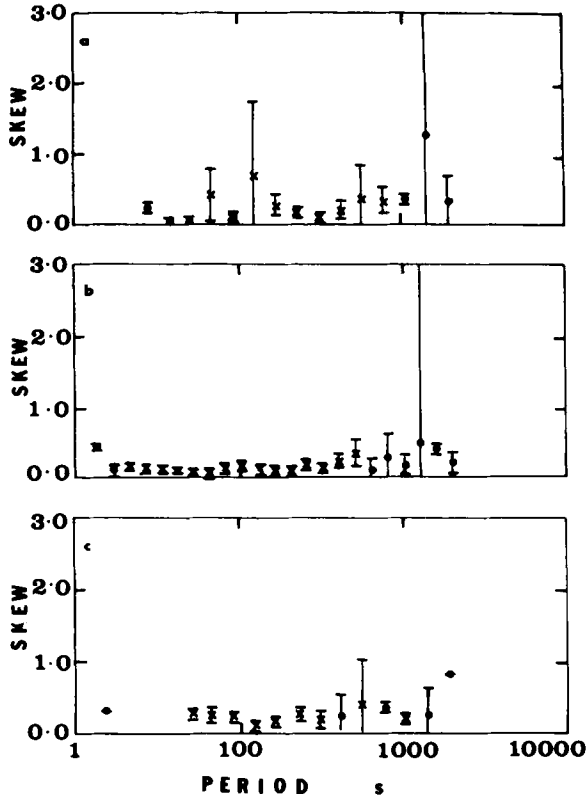

Figure 10. The skew values for BOR (a), NEW (b) and PRE (c).

obviously two- (or even three-) dimensional Southern Uplands Fault, have not yet been interpreted.

The minimum in the major apparent resistivity curve at 50 s and the maximum at 200 s observed at ESK are not consistent with the results from sites BOR, NEW and PRE. Therefore, general models which satisfy the data from these three locations will not be acceptable to the ESK response. As the object of this preliminary interpretation was to find a general model of the conductivity distribution beneath the Southern Uplands, the data from ESK also have not yet been fully interpreted. It is possible that, at this station, the ρ_{minor} results should be interpreted since they are reasonably consistent with the ρ_{major} curves from PRE, BOR and NEW.

A high telluric noise level was present in the observations at both DZR and GOR. This resulted in the rejection of over 80 per cent of the estimates of rotated major impedances and a high degree of scatter of those acceptable. It was thus concluded that the MT data were grossly corrupted by cultural electrical disturbances and were not meaningful. During fieldwork at CAP, the north-south telluric line had to be relocated because of obvious interference from a mains transformer in the vicinity. As the resistivity estimates at this site differed from those from CRK, ESK and NEW, it was considered that the data may not reflect the true conductivity distribution but indicate the distortion of the natural telluric field. For TIN also, the MT results have not yet been interpreted since they are not consistent with those from other Southern Uplands stations.

It has been assumed that, in general, the inconsistent stations have indicated three-dimensional features which would be difficult to model at this early stage.

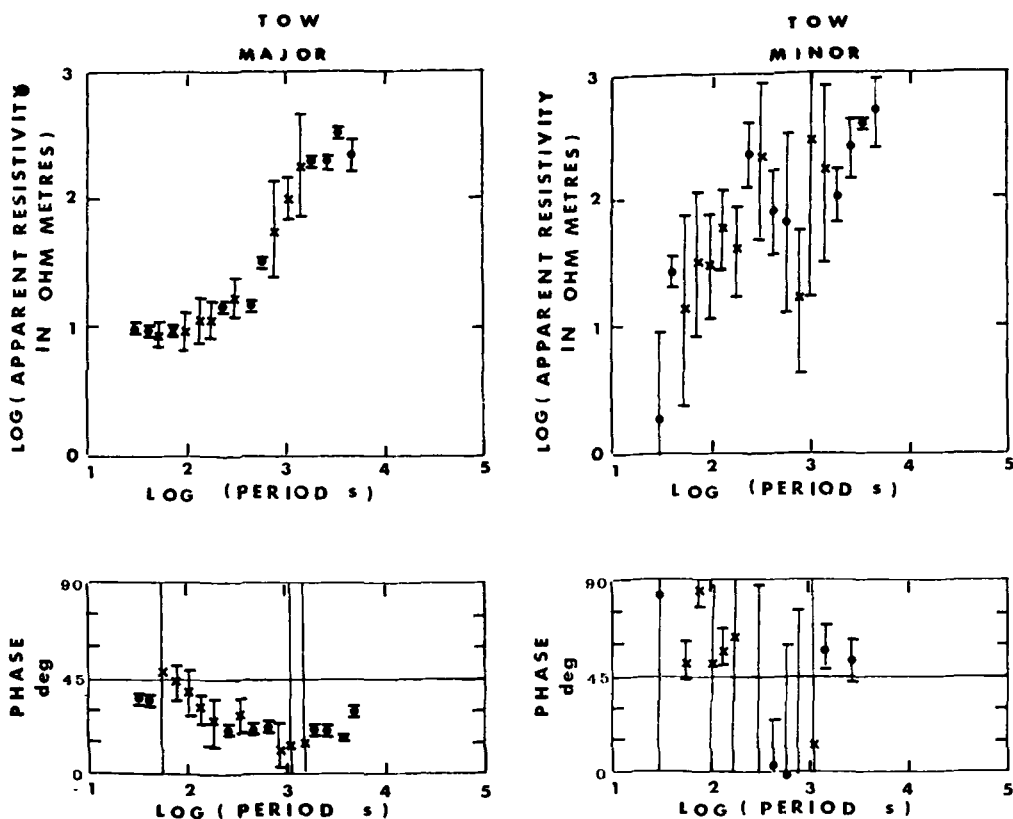

Figure 11. Rotated major and minor magnetotelluric responses for Towhouse, TOW. 95 per cent confidence limits are shown.

5 Discussion of results

5.1 JUSTIFICATION FOR ONE-DIMENSIONAL INTERPRETATION AT CERTAIN SITES

The validity of a one-dimensional interpretation of MT data has been the subject of much discussion since Tikhonov and Cagniard first proposed the magnetotelluric method. If the conductivity varies significantly in one, or both, horizontal directions, then a one-dimensional interpretation of the data is open to criticism. If, however, the apparent resistivity data are isotropic, e.g. $\rho_{xy}(f) = \rho_{yx}(f)$ for all frequencies f , it may be safely concluded that the conductivity beneath the recording site only varies significantly with depth. When two further effects are observed, i.e. zero skew and no preferred maximizing orientation, then the assumption can be made with even greater confidence. The data from sites BOR and NEW display all three of these indicators and hence one-dimensional interpretations of their responses are certainly valid. Also, BOR, NEW and PRE exhibit similar responses, which is additional evidence for assuming that a one-dimensional model is valid for the central north-east/south-west zone of the Southern Uplands.

For locations in the centre of a conducting graben, Reddy & Rankin (1972) have shown that the conductivity variation with depth can be derived by interpreting the E -polarization apparent resistivity curve (i.e. ρ_{11}) in a one-dimensional sense. The E -polarization data for

such a site are given by the ρ_{major} and ϕ_{major} curves. The H -polarization curve (ρ_{\perp}) is shown to be frequency independent at the value of the graben resistivity. Reddy & Rankin also showed that the magnetic field component normal to the strike of a graben-like anomaly is altered by the secondary field generated by induction. This results in a change in the polarization characteristics of the total magnetic field such that the magnetic field at sites above the conducting graben has a tendency to orient itself normal to the strike direction. The 'minor' data from TOW exhibit a frequency independence. Since, in addition, this site was located above the east-west striking Northumberland sedimentary basin, and the magnetic field there had a predominantly north-south polarization, it was concluded that a one-dimensional interpretation of the rotated major data from TOW would give a valid conductivity distribution with depth at this station.

Wright (1970) studied the problem of the perturbation of electromagnetic fields by a two-dimensional structure in his discussion of a possible Rhine-graben model. His interest was in the anisotropy of the tensor elements Z_{xy} and Z_{yx} caused by the structure. He showed that at a sufficiently large distance from a lateral inhomogeneity, in his case 15 km, the H - and E -polarization apparent resistivity and phase curves were very similar, both in shape and in magnitude. In addition he found that:

- (a) a one-dimensional interpretation of either yielded the correct resistivity-depth profile beneath the location,
- (b) at locations close to a lateral inhomogeneity, the two polarizations gave widely different responses, both in magnitude and in phase,

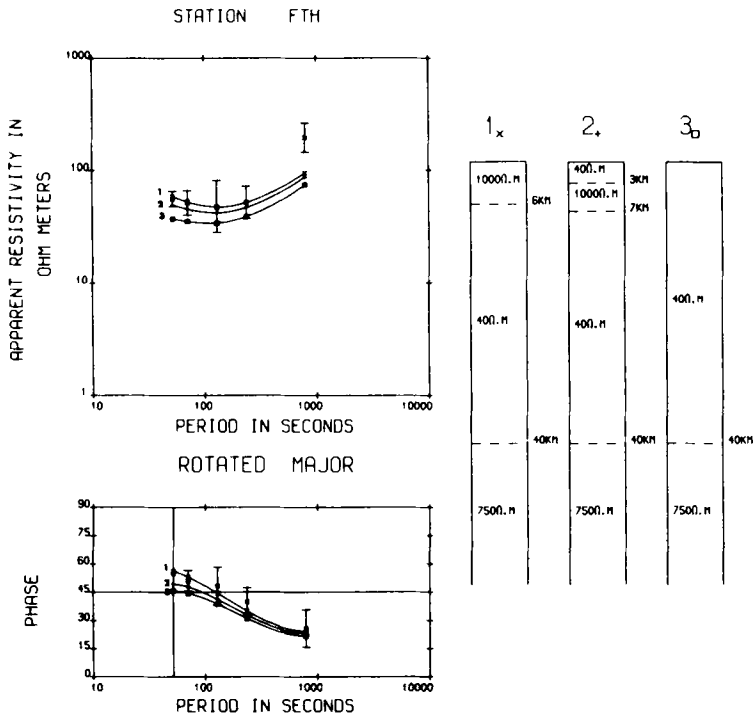

Figure 12. Comparison of theoretical and observed magnetotelluric responses for Forth, FTH. The smooth curves represent the theoretical responses for the models shown.

(c) on the resistive side of a lateral inhomogeneity, and close to that inhomogeneity, a one-dimensional interpretation of the H -polarization curve (ρ_{\perp}) gave a structure with correct interface depths but over-estimated layer resistivities, and

(d) the overestimation factor, the logarithm of which is the same for all layers, could be obtained from the long period E -polarization resistivities (ρ_{\parallel}) because, at long periods, the Cagniard and E -polarization curves coalesce. For locations on the resistive side of the inhomogeneity, it is the ρ_{major} and ϕ_{major} data which represent the H -polarization case.

Hence, for MT data which appear two-dimensional - as at FTH and SAL - an interpretation of the major impedance data appears to give correct interface depths. If the observational location is on the conductive side of the lateral inhomogeneity the layer resistivities are also correct, but, if not, they have to be multiplied by the overestimation factor.

5.2 COMPARISON OF THEORETICAL AND OBSERVED MT RESPONSES

The forward problem of calculating the response function measured at the surface of an n -layered isotropic half-space has been considered by many workers (e.g. Ward, Peebles &

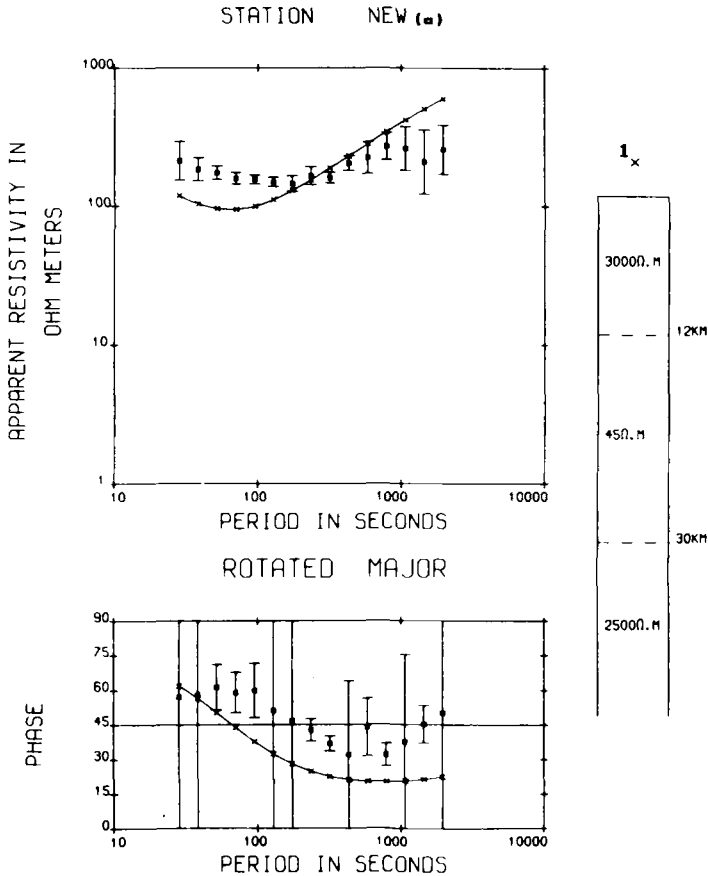

Figure 13. (a) Comparison of the observed magnetotelluric responses for Newcastleton, NEW and the theoretical responses based on Jain & Wilson's model for the Southern Uplands - model 1.

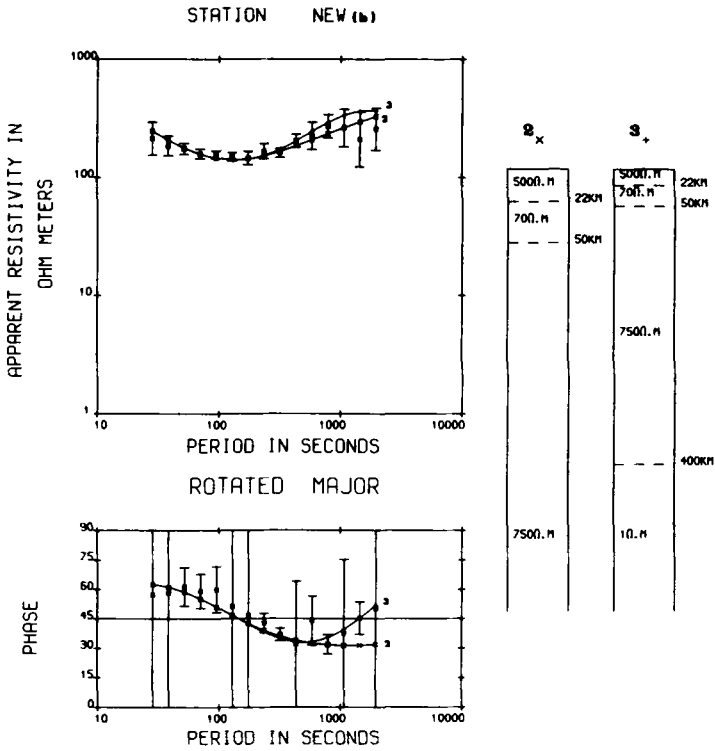

Fig. 13. (b) Comparison of the observed magnetotelluric responses for NEW and the theoretical responses for models 2 and 3 shown.

Ryu 1973). Using the algorithm of Lipskaya & Troitskaya (1955) (reproduced in Keller & Frischknecht 1966) for calculation of the complex response, an attempt was made to fit theoretical response curves to the observational data from several of the sites. Only very limited modelling of this type was undertaken in view of the non-uniqueness of this method. It nevertheless proved useful in providing some insight into the most critical model parameters and as a starting point for application of Monte-Carlo inversion techniques, to be reported in part II.

Computed apparent resistivity and phase versus period curves for the models indicated are superimposed on the plots of values estimated from the field data from (a) FTH, as representative of the Midland Valley – Fig. 12, (b) NEW, as representative of the Southern Uplands – Fig. 13(a) and (b), and (c) TOW – Fig. 14. Although further magnetotelluric observations in northern England are necessary to confirm that the responses obtained at TOW are representative of the Northumberland Basin, there is already supporting evidence from geomagnetic deep sounding observations (Grimes 1977; Hutton & Jones 1978) that marked lateral variations in conductivity structure exist in this region.

For Forth, computed curves are shown for three models in which all or most of the crust has a low resistivity. The model which best fits the well-estimated amplitude data is model 1 in which the top of the conducting region is 6 km below the surface. Neither the addition of a superficial conductor to allow for the effect of sedimentary cover nor the extension of the conducting region to the surface results in a better fit with observed data. The fact that the observed increase in apparent resistivity with period between 100 and 1000 s is greater than in the model curves is compatible with the longer-period data being less suited to a one-dimensional interpretation.

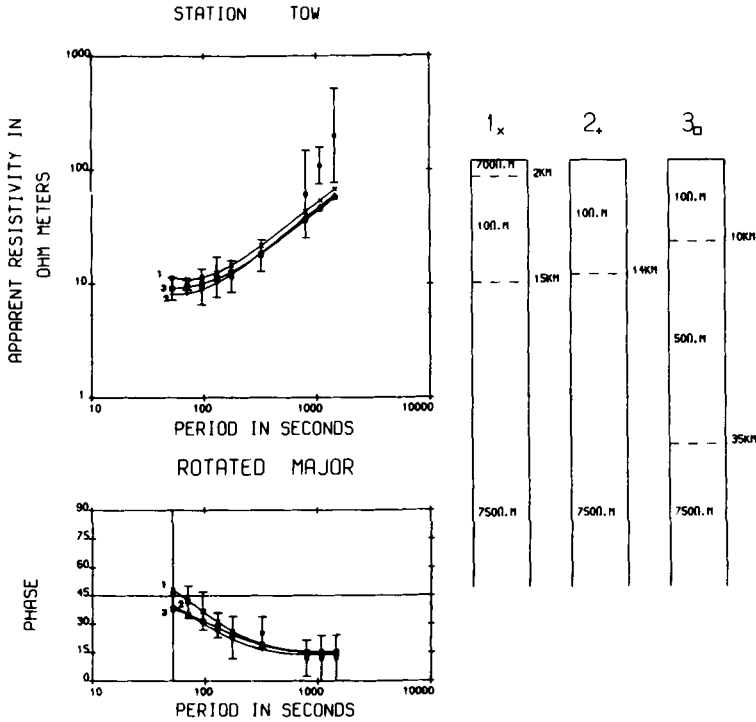

Figure 14. Comparison of the observed magnetotelluric responses for Towhouse, TOW and the theoretical responses for models 1, 2 and 3 shown.

For Newcastleton, computed curves are drawn for three models, model 1 (Fig. 13(a)) corresponding to that suggested for Eskdalemuir by Jain & Wilson. This model, with a conducting layer at 12 km depth under the Southern Uplands, does not provide a good fit with the NEW data. Better agreement is obtained with a conducting layer at a depth of 25 km and the addition of a second conducting layer at 400 km improves the fit with the longer period phase data (Fig. 13(b)).

Three models are shown for Towhouse (Fig. 14). As for Forth, the rapid increase in apparent resistivity with period observed at TOW cannot easily be modelled one-dimensionally. With the exception of the two longest period apparent resistivity values, the computed curves for all three models fit the observations well and clearly indicate the existence of a very highly conducting upper crust in the region of this station.

The limited forward modelling described in this paper has shown that there are marked changes in electrical conductivity structure in the crust and upper mantle in the region extending from the Midland Valley across the Southern Uplands into northern England. The major features observed are confirmed by Monte-Carlo inversion of the data, presented in part II, in which the geophysical and geological implications are also discussed.

Acknowledgments

This study has been undertaken with the support of the Natural Environment Research Council both in the form of a Research Grant and a Research Studentship to one of us (AGJ). The authors gratefully acknowledge this support and also that from the University of Edinburgh and the Royal Society, London, for much of the fieldwork instrumentation.

We are also indebted to Alex Jackson, Hugh Muir, Surrinder Chita and many others for fieldwork and technical assistance, to Beth Egan and Kathy Dodds for their careful and speedy digitizing and typing respectively, and to all those on whose land our observations were made. Their great generosity and hospitality made the fieldwork most enjoyable.

Colleagues in the induction group in the Department of Geophysics, University of Edinburgh, have made many helpful suggestions in the course of this work.

References

- Bailey, R. C. & Edwards, R. N., 1976. The effect of source field polarization on geomagnetic anomalies in the British Isles, *Geophys. J. R. astr. Soc.*, **45**, 97–104.
- Bailey, R. C., Edwards, R. N., Garland, G. D., Kurtz, R. & Pitcher, D. H., 1974. Electrical conductivity studies over a tectonically active area in Eastern Canada, *J. Geomag. Geoelectr.*, **26**, 125–146.
- Bamford, D., Faber, S., Jacob, B., Kaminski, W., Nunn, K., Prodehl, C., Fuchs, K., King, R. & Willmore, P., 1976. A lithosphere seismic profile in Britain – I. Preliminary results, *Geophys. J. R. astr. Soc.*, **44**, 145–160.
- Batschelet, E., 1965. Statistical methods for the analysis of problems in animal orientation and certain biological rhythms, *Am. Inst. Biol. Sci.*, Washington, DC.
- Briden, J. C., Morris, W. A. & Piper, J. D. A., 1973. Palaeomagnetic studies in the British Caledonides – IV. Regional and global implications, *Geophys. J. R. astr. Soc.*, **34**, 107–134.
- Dewey, J. F., 1974. The geology of the southern termination of the Caledonides, in *The Ocean Basins and Margins, Vol. 2 The North Atlantic*, Plenum Press, New York.
- Edwards, R. N., Law, L. K. & White, A., 1971. Geomagnetic variations in the British Isles and their relation to electrical currents in the ocean and shallow seas, *Phil. Trans. R. Soc. Lond.*, **270**, 289–323.
- Fowler, R. A., Kotich, B. J. & Elliot, R. D., 1967. Polarisation analysis of natural and artificially induced geomagnetic micropulsations, *J. geophys. Res.*, **72**, 2871–2883.
- Garland, G. D., 1975. Correlation between electrical conductivity and other geophysical parameters, *Phys. Earth planet. Int.*, **10**, 220–230.
- Gough, D. I., 1973. The geophysical significance of geomagnetic variation anomalies, *Phys. Earth planet. Int.*, **7**, 379–388.
- Grillot, L. R., 1975. Calculation of the magnetotelluric tensor impedance: Analysis of band limited MT signal pairs, *Geophysics*, **40**, 796–797.
- Grimes D. F., 1977. Geomagnetic Deep Sounding in north-west England, *MSc thesis*, University of Lancaster.
- Hermance, J. F. 1973. Processing of magnetotelluric data, *Phys. Earth planet. Int.*, **7**, 349–364.
- Hutton, V. R. S., 1976. Induction studies in rifts and other active regions, *Acta Geodet. Geophys. Montanist*, **11**, 347–376.
- Hutton, V. R. S. & Jones, A. G., 1978. Magnetovariational and magnetotelluric investigations in S. Scotland, *J. Geomag. Geoelectr.*, in press.
- Hutton, V. R. S., Sik, J. M. & Gough, D. I., 1977. Electrical conductivity and tectonics of Scotland, *Nature*, **266**, 617–620.
- Jain, S. & Wilson C. D. V., 1967. Magnetotelluric investigations in the Irish Sea and Southern Scotland, *Geophys. J. R. astr. Soc.*, **12**, 165–180.
- Jenkins G. M. & Watts D. G., 1968. *Spectral Analysis and its Application*, Holdon-Day.
- Jolivet, J., 1966. *PhD thesis*, University of Paris.
- Jones, A. G., 1977. Geomagnetic induction studies in S. Scotland, *PhD thesis*, University of Edinburgh.
- Jones, A. G. & Hutton, V. R. S., 1977. Magnetotelluric investigation of the Eskdalemuir anomaly – preliminary results, *Acta Geodet. Geophys. Montanist*, **12**, 111–115.
- Keller, G. V. & Frischknecht, F. C., 1966. *Electrical Methods in Geophysical Prospecting*, Pergamon Press, Oxford.
- Kurtz, R., 1973. A magneto-telluric investigation of Eastern Canada, *PhD thesis*, University of Toronto.
- Law, L. K. & Riddihough, R. P., 1971. A geographical relation between geomagnetic variation anomalies and tectonics, *Can. J. Earth Sci.*, **8**, 1094–1106.
- Mardia, K. V., 1972. *Statistics of Directional Data*, Academic Press, New York.
- Moseley, F., 1977. Caledonian plate tectonics and the place of the English Lake District, *Geol. Soc. Am. Bull.*, **88**, 764–768.

- Osemeikhian, J. E. A. & Everett, J. E., 1968. Anomalous magnetic variations in southwestern Scotland, *Geophys. J. R. astr. Soc.*, **15**, 361–366.
- Rankin, D., Reddy, I. K. & Schneider, K., 1976. On the interpretation of continuous resistivity distributions in the magnetotelluric method, *Geophys. J. R. astr. Soc.*, **45**, 89–95.
- Reddy, I. K., Phillips, R. J., Whitcomb, J. H., Cole, D. M. & Taylor, R. A., 1976. Monitoring of time-dependent electrical resistivity of magnetotellurics, *J. Geomag. Geoelectr.*, **28**, 165–178.
- Reddy, I. K. & Rankin, D., 1972. On the interpretation of magneto-telluric data in the Plains of Alberta, *Can. J. Earth Sci.*, **9**, 514–527.
- Reddy, I. K. & Rankin, D., 1974. Coherence functions for magnetotelluric analysis, *Geophysics*, **39**, 312–320.
- Rooney, D. & Hutton, V. R. S., 1977. A magnetotelluric and magnetovariational study of the Gregory Rift Valley, Kenya, *Geophys. J. R. astr. Soc.*, **51**, 91–119.
- Sims, W. E., Bostick, F. N. & Smith, H. W., 1971. The estimation of magnetotelluric impedance tensor elements from measured data, *Geophysics*, **36**, 938–942.
- Swift, C. M., 1967. A magneto-telluric investigation of an electrical conductivity anomaly in the southwestern United States, *PhD thesis*, Department of Geology & Geophysics, MIT, Cambridge, Massachusetts.
- Trigg, D. F., Serson, P. H. & Camfield, P. A., 1971. *Publ. Earth Phys. Branch*, **41** (5), 66.
- Vozoff, K., 1972. The magnetotelluric method in the exploration of sedimentary basins, *Geophysics*, **37**, 98–141.
- Ward, S. H., Peebles, W. J. & Ryu, J., 1973. Analysis of geomagnetic data, in *Methods of Computational Physics, Vol. 13, Geophysics*, Academic Press, New York.
- Wilson, J. T., 1966. Did the Atlantic close and then re-open? *Nature*, **211**, 676–681.
- Wright, J. A., 1970. Anisotropic apparent resistivities arising from non-homogeneous two-dimensional structures, *Can. J. Earth Sci.*, **7**, 527–531.